

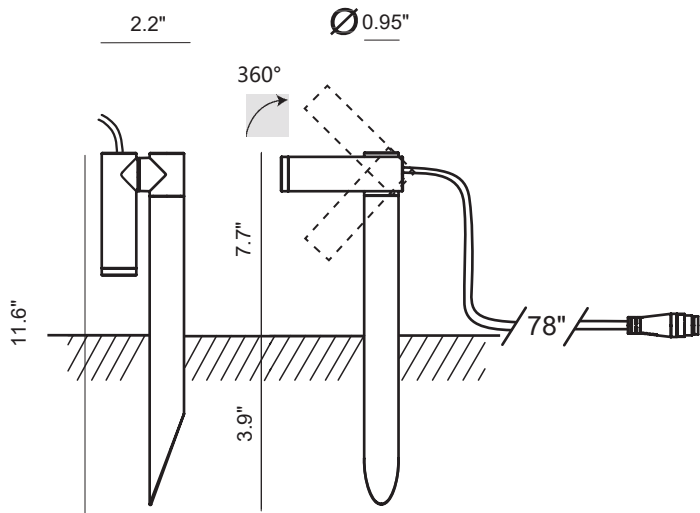

AXENT



AXENT - H3733



LED solar lamp
IP65



Materials:

- die-casting aluminium, extruded aluminium
 - thermosetting epoxy polyester powder coating
 - stainless steel screws
 - clear glass diffuser
- Salt spray corrosion test: 800h

Power: 2.2W

Working time:

- with 4x2.2W Lamps: 26-28 Hours

LED: Lumileds 5050

Light colour temperature: 3000K

CRI>80

2m cable with IP68 connector

Inner box size: 3.5" x 2.75" x 12"

Master: 6 pieces

Master size: 9.1" x 7.7" x 13.6"

Net weight: 3.75 lbs

Gross weight: 7.3 lbs

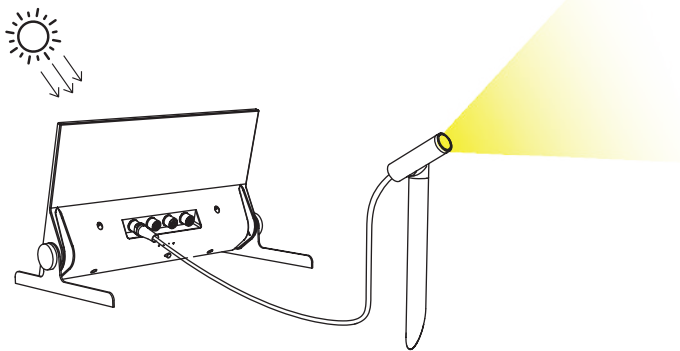

MAX 4 LAMPS

