

# mr.GO!

## LED Lantern

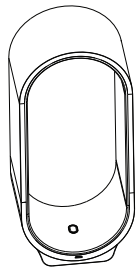

mr.GO!



USB charger & cable

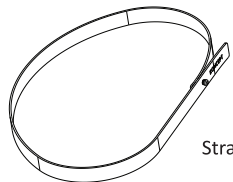

Strap

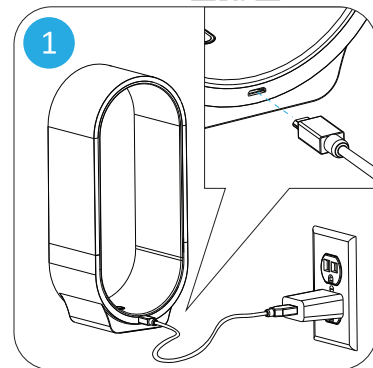

Connect the USB cable & charger to the mr.GO! and start charging. The indicator light will be pulsing green when it is charging. Once it is fully charged the indicator will be off.

*\*mr.GO! must be connected to power before first use.*

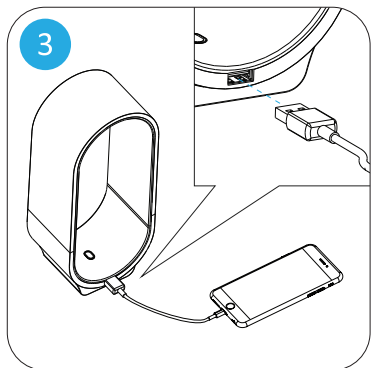

Charge your phone with the USB port.

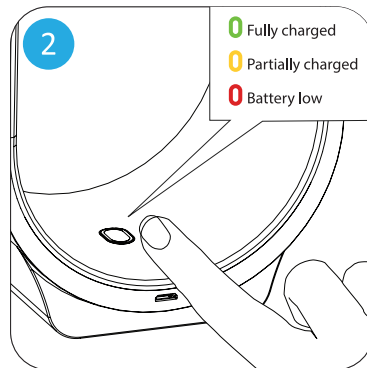

- Fully charged
- Partially charged
- Battery low

Press the button to turn mr.GO! on or off, or hold it to dim/brighten the light. Press once to have battery indicator light show for 5 seconds.

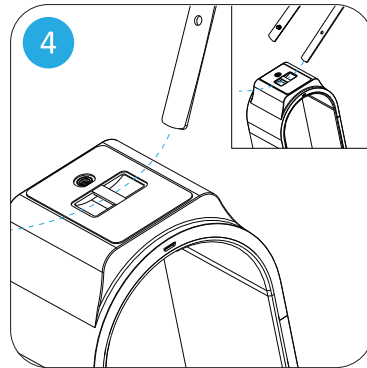

Optional: Fit the provided strap through the hole underneath the mr.GO! to hang the mr.GO! upside down to use as an ambient light.

## KONCEPT

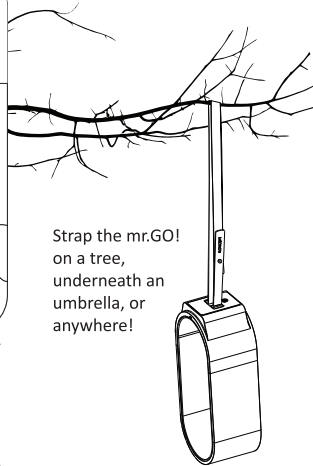

Strap the mr.GO! on a tree, underneath an umbrella, or anywhere!

### One Year Limited Product Warranty

Koncept warrants to the original purchaser of this product against manufacturer defects in design, assembly, material, or workmanship, and will, at Koncept's option, replace or repair any defective product free of charge. This coverage is valid for one year from the date of purchase as long as the original purchaser owns the product. Koncept will replace or repair the product, which Koncept, at its sole discretion, agrees is defective, free of charge provided that the following conditions for a return are fulfilled.

This warranty does not apply to any product damaged by accident, physical or electrical misuse or abuse, improper installation, alteration, any use contrary to its intended function, war, fire, flood, or any other acts of nature, or unauthorized repair.

Koncept assumes no liability for any events such as fines arising out of the use of this product or any consequential damages caused by any failure of the product to function properly. Under no circumstances should this warranty or the product covered by it be construed as an insurance policy against loss of any kind. Koncept staff neither assumes nor authorizes any person or organization to make any warranties or assume any liability in connection with the sale or use of this product. This warranty covers only products used in the 50 US states and/or Canada. This is the complete NLG warranty and no other warranty exists. Some jurisdictions may not allow limitations on how long an implied warranty lasts, or the exclusion or limitation of incidental or consequential damages, so the above exclusions or limitations may not apply to you. This warranty gives you specific legal rights, and you may also have other rights which vary in different states and countries.

To file a replacement/repair claim under the warranty:

- 1) Contact Koncept for a return authorization number during the warranty period. A claim will not be accepted without a return authorization number.
- 2) Make a copy of the original purchase receipt with purchase date and product name clearly shown.
- 3) Provide original purchaser's full name, email address (optional), daytime phone, and postal address.
- 4) Return the defective product to Koncept freight prepaid and accompanied by (1), (2), and (3) to the following address:

Limited Product Warranty Koncept Inc. 429 E. Huntington Drive, Monrovia, CA 91016

### Warnings



**Warning: To reduce the risk of fire, electric shock or injury:**

- Use in dry locations only
- Do not handle plug or appliance with wet hands
- Do not stare directly at LEDs



**Overheating may result in reduced LED lifespan:**

- Keep out of direct sunlight.
- Remove plastic bag from lamp before use.
- Recommended ambient temperature: under 77 °F.

### Specifications

Model	NLG-S
Light Color	Soft White
Color Temperature	2,700 K
Brightness Adjustability	Continuous

Koncept Inc.  
429 E. Huntington Drive  
Monrovia, CA 91016, USA  
Phone: 323-261-8999  
Fax: 323-261-8998

Customer Support:  
support@koncept.com

Web Address:  
www.koncept.com

Register your Koncept LED lamp online and receive:

- One Year Warranty Extension
  - Priority Product Servicing
- Visit [www.koncept.com/productsupport](http://www.koncept.com/productsupport) and enter your serial number (S/N: XXXXXXXX) located on your product.