

4

3

2

1

REVISIONS

REV	EC NO.	DESCRIPTION	DATE	APPROVED
A		Release	10/13/2021	

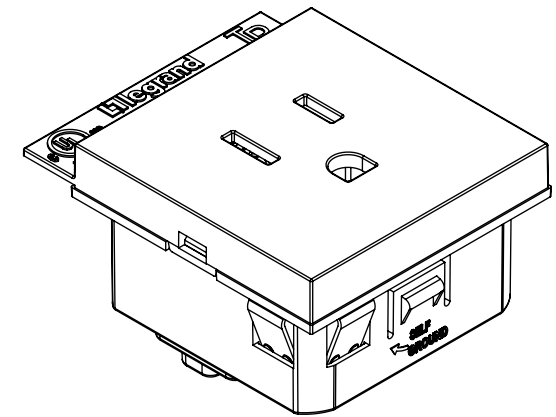
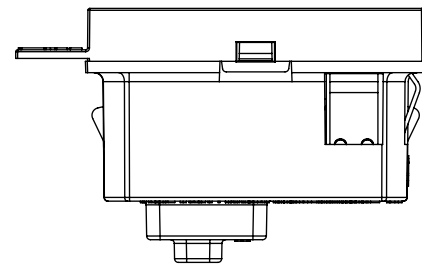
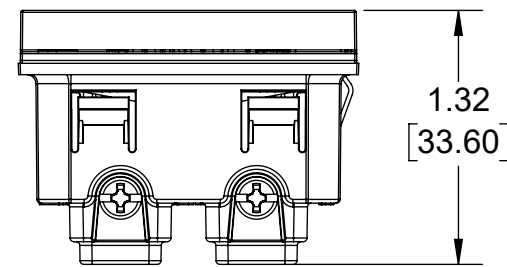
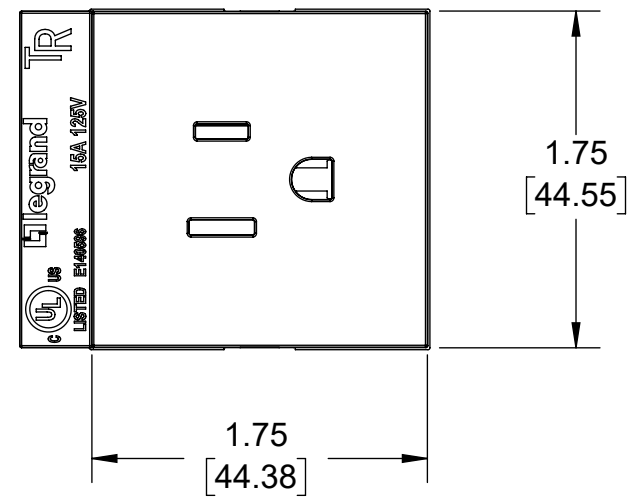

NOTES:

1. BASE CATALOG NUMBER - ARTR151
2. ELECTRICAL RATING - 15A., 125V., 60HZ.
3. HOUSING MATERIAL- POLYCARBONATE
4. 3rd PARTY LISTING - cULus LISTED
5. MUST BE USED WITH LEGRAND ADORNE MOUNTING AND WALL PLATE SYSTEM.
6. SCREW TERMINALS ACCEPT #12 -14 AWG COPPER WIRE ONLY.
7. TERMINALS WILL ACCEPT ONE OR TWO WIRES FOR FEED-THRU WIRING.

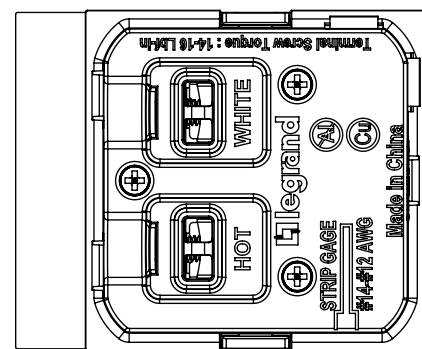

ENVIRONMENTAL MATERIAL REQUIREMENTS

MATERIALS, PRODUCTS, PARTS AND ASSEMBLIES PROVIDED UNDER THIS DRAWING MUST MEET THE REQUIREMENTS DETAILED IN THE LATEST REVISION OF THE LEGRAND, NORTH & CENTRAL AMERICA CORPORATE ENVIRONMENTAL MATERIAL REQUIREMENTS (EMR) DOCUMENT EMS-009. ANY DEVIATION FROM THE EMR REQUIREMENTS MUST BE APPROVED BY AN AUTHORIZED REPRESENTATIVE OF LEGRAND PRODUCT ENGINEERING IN WRITING. THE LATEST EMR DOCUMENT IS AVAILABLE ON REQUEST.

Unspecified Tol. Frac $\pm 1/64$ Angles ± 1.0	Tool Number:	Finish:	Drawing Title	Scale: 1:1 Sheet: 1 of 1	Recom Drawing No: Rev. A
	Material:	CUSTOMER DRAWING FOR ADORNE SINGLE OUTLET			
	Part Weight:	Date:	legrand	Model Number: ARTR151	P&S Drawing No. CAD3201-PS-ARTR151
	Created By: JR	10/13/2021			
Do Not Scale Drawing	Checked By:	Date:	NOTICE: Proprietary and confidential information of Pass & Seymour/Legrand. Reproduction or disclosure prohibited under penalty of law.		

4

3

2

1