

BL300D Series LED Barn Light

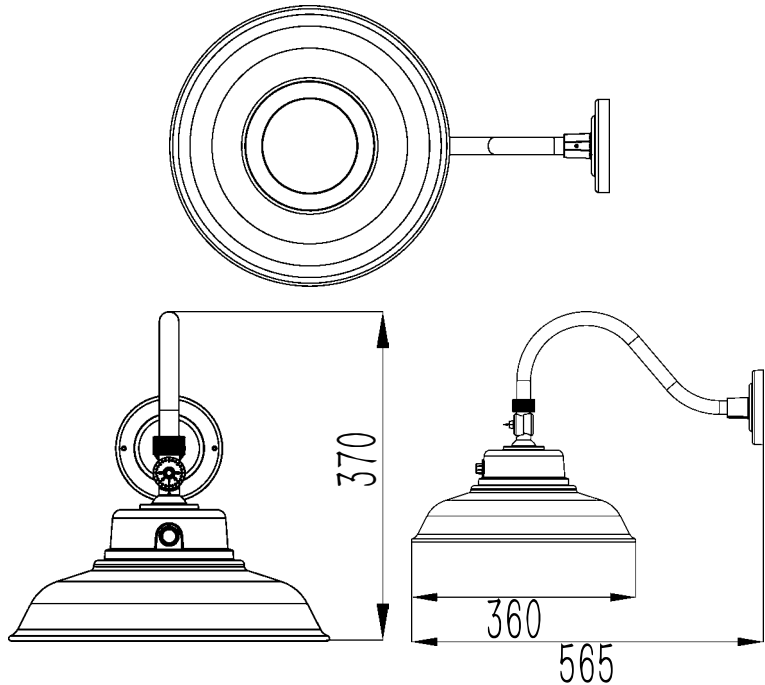

Introduction

The BL300L Series use AC DOB LED light technology, distills the benefits of the latest in LED technology into a high performance, high efficacy, long-life luminaire. The outstanding photometric performance results in sites with excellent uniformity, greater pole spacing and lower power density. It is ideal for replacing up to 250W mercury vapor luminaire while saving 70% in energy costs. The BL300 Series eliminates frequent lamp and ballast replacements associated with traditional technologies. Can be wall mounted .



ORDERING INFORMATION

EXAMPLE:BL301L-40W-WH-CCT-PCS

Model	Power	FINISH	Color	Options
BL301L	40W	BR Brown	30K 40K 50K	NPC No photocontrol PCS Electronic type Coin-type photoelectric Switch
		WH White		
		RE RED		
		BL BLUE		

ELECTRICAL SYSTEM

- Input Voltage: 120-277Vac , 50/60Hz
- Power Factor : > 0.98 at full load
- Total Harmonic Distortion: < 15% at full load
- 0(1)-10V Dimming Range:Continuous Dimming to 10%or below
- Integral 2.5kV surge suppression protection standar.
- Luminaire is qualified to operate at ambient temperatures of -40°C to +50°C

Notes

- Photocontrol (PE) requires 120/240/277 voltage or short cap optional.
- Features an ultra-durable powder topcoat, providing excellent resistance to corrosion, ultraviolet degradation and abrasion. Gray, silver, black, bronze, platinum bronze , white and so on are available.

INSTALLATION

Easily mounts to a wooden post or pole using 2" lag screws, included. Compatible with 1-5/8" mounting arm, sold separately.

REGULATORY & VOLUNTARY QUALIFICATIONS

- UL Listed.
- Suitable for wet locations.
- Certified to ANSI C136.31-2001, 3G vibration standards.
- 2.5kV surge suppression protection tested in accordance with IEEE/ANSI C62.41.2.
- Meets FCC Part 15 standards for conducted and radiated emissions.
- Luminaire and finish endurance tested to withstand 3,000 hours of elevated ambient salt fog conditions as defined in ASTM Standard B 117.
- RoHS compliant. Consult factory for additional details.
- DesignLights Consortium ®(DLC) qualified product. Not all versions of this product may be DLC qualified. Please check the DLC Qualified Products List at www.designlights.org to confirm which versions are qualified.

WARRANTY

- 5 years limited warranty is standard on luminaire and components.

BL300 Series Performance Data

Lumen Output

Lumen values are from photometric tests performed in accordance with IESNA LM-79-08. Data is considered to be representative of the configurations shown, within the tolerances allowed by Lighting Facts. Actual performance may differ as a result of enduser environment and application. Actual wattage may differ by +/- 10% when operating between 120-277V +/- 10%. Contact factory for performance data on any configurations not shown here.

MODEL	LEDS	LED CURRENT	RATED WATTS	30K(3000K,70CRI)		40K(4000K,70CRI)		50K(5000K,70CRI)	
				LUMENS	LPW	LUMENS	LPW	LUMENS	LPW
BL301L	120	100mA	40W	4800	120	4800	120	4800	120

Photometric Diagrams

To see complete photometric reports or download .ies files for this product
Isfootcandle plots for the BL301L. Distances are in units of mounting height (15')

Electrical Data

MODEL	LEDS	LED CURRENT	SYSTEM WATTS	Current		
				120	240	277
BL301L	120	100mA	40W	0.33	0.16	0.14

Lumen Ambient Temperature (LAT) Multipliers

Ambient		Lumen Multiplier
0°C	32°F	1.02
10°C	50°F	1.01
20°C	68°F	1.00
25°C	77°F	1.00
30°C	86°F	1.00
40°C	104°F	0.99

Luminaire Lumen Maintenance Factors (LMF)

Data references the extrapolated performance projections for the platforms noted in a 25°C ambient, based on 10,000 hours of LED testing (tested per IESNA LM-80-08 and projected per IESNA TM-21-11).

To calculate LLF, use the lumen maintenance factor that corresponds to the desired number of operating hours below. For other lumen maintenance values, contact factory.

Operating Hours	0	25000	50000	75000	100000
Lumen Maintenance Factor	BL301L 120 LED 0.1A				
	100%	96%	94%	92%	90%