

# 2'x 2' Panel

20W, 30W, 40W Selectable | 3CCT | 120-347V

High performance, light-weight luminaires suitable for lay-in, surface or pendant mounting. Ideal for use in schools, health care applications, offices, retail spaces, and more

Less than 1.8" Deep  
ideal for tight plenum areas

Use Switch to  
Select Power  
and Colour



0-10V Dimming Lead on Both  
Sides of Driver Junction Box

120-347V, 0-10V  
Dimmable Driver

Power Selectable  
(20W / 30W / 40W)

Waffle Stamping  
increases heat  
dissipation and  
driver life

Seismic Clips  
Included



Colour Selectable  
(3500K / 4000K / 5000K)



Junction Box (PLS-JB)  
sold separately

Accessories (Sold Separately)



Suspension Kit  
PLS-SUSKIT



Surface Mount Kit  
PLS22-SK



Junction Box  
PLS-JB



Recessed Frame Kit  
PLS22-RFK

## TECHNICAL DATA



### LIGHT SPECIFICATIONS

Efficacy	111 lm/W
CCT	3500K/4000K/5000K
CRI	84
Dimmable	0-10V
Beam Angle	120°
L70 Life	50,000 hrs
Warranty	7-year

LUMEN OUTPUT			
	3500K	4000K	5000K
20W	2664 lm	2757 lm	2656 lm
30W	3724 lm	3930 lm	3727 lm
40W	4375 lm	4678 lm	4345 lm

### APPROVALS AND LISTINGS

ETL	5000444
DLC	S-UHQD2I

### DIMENSIONAL DRAWINGS (IN)

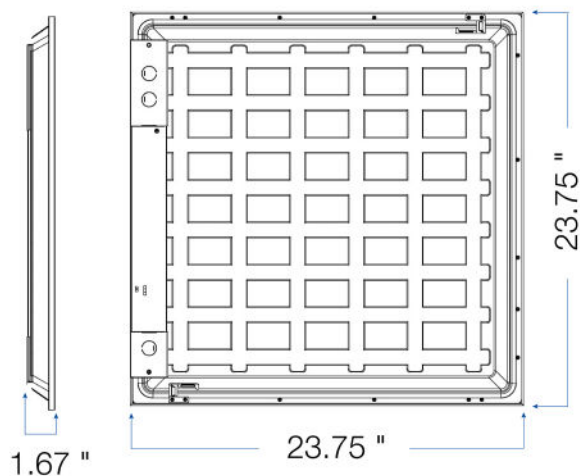

### ELECTRICAL

Wattage	Selectable (20W/30W/40W)
Voltage	120-347V
Current	0.44A
Power Factor	0.93
THD	<20%
Operating Temp	-20 to 40°C

### CONSTRUCTION

Housing	Metal
Finish	Polyester Powder Coat
Finish Colour	White
IP Rating	IP20

### DIMENSIONS & WEIGHTS

Fixture Weight	4.2 lbs
Fixture Dimensions	23.75" x 1.67" x 23.65"
Carton Qty	4 pcs
Carton Weight	19 lbs
Carton Dimensions	24.7" x 7" x 25"

### ACCESSORIES (SOLD SEPARATELY)

PLS22-SK	Surface Mount Kit
PLS22-RFK	Recessed Frame Kit
PLS-SUSKIT	Suspension Kit
PLS-JB	Junction Box