

# LHB04 Linear High Bays

Power Selectable | Colour Selectable | 120-347V

The successor to our best-selling LHB03 Linear High Bays!

Ideal for warehouses, factories, workshops, and more

Energy efficient replacement for traditional fluorescent fixtures and HID high bays



Power Selectable  
110W / 130W / 150W

0-10V Dimmable

Complete with 10'  
Cord Whip

Colour Selectable  
3500K / 4000K / 5000K



Centre Knockout Allows  
for Easy Installation of an  
Optional Motion Sensor  
(sold separately)

Newly Designed,  
Shatterproof  
Polycarbonate Optics  
meet/exceed DLC 5.1  
glare standards

Strong Die Cast  
Housing  
and reduced size for  
easy installation

\*Mounting Hooks Included

## TECHNICAL DATA



### LIGHT SPECIFICATIONS

Efficacy	140 lm/W
CCT	3500K / 4000K / 5000K
CRI	>80
Beam Angle	90°
Dimmable	0-10V
L70 Life	50,000 hrs
Warranty	5-year

LUMEN OUTPUT			
	3500K	4000K	5000K
110W	15437 lm	16275 lm	15960 lm
130W	17780 lm	19155 lm	18551 lm
150W	19745 lm	21483 lm	20790 lm

### DIMENSIONS AND WEIGHTS

Fixture Weight	4.2 lbs
Fixture Dimensions	14.17" x 11.02" x 1.89"
Carton Qty	1
Carton Weight	5.95 lbs
Carton Dimensions	15" x 11.8" x 3.4"

### DIMENSIONAL DRAWINGS

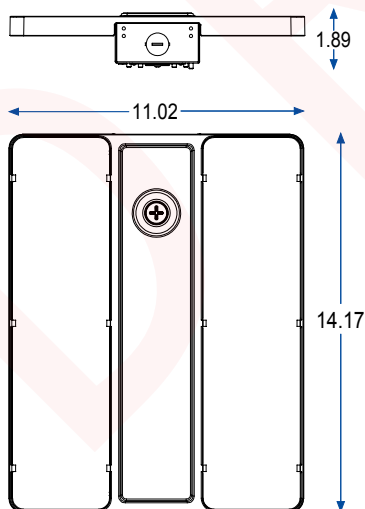

### ELECTRICAL

Wattage	110W / 130W / 150W
Voltage	120-347V
Current	1.60A
Surge Protection	6kV
Auxiliary Output	12V
Power Factor	≥0.9
THD	≤20%
Operating Temp	-40 to 50°C

### CONSTRUCTION

Cord Whip	10'
Housing	Die Cast Aluminum & Steel
Lens	Polycarbonate
Finish	Powder Coated
Finish Colour	White
IP Rating	IP20

### ACCESSORIES (Ordered Separately)

Pendant Mount	LHB04-BKT
Surface Mount	LHB04-SK
Microwave Motion Sensor	MS04-MW-TW-DC
Infrared Motion Sensor	MS01-PIR-TW-DC
Remote Control	HB01R
Wire Guard	LHB04-WG-SM

### APPROVALS & LISTINGS

cUL	E482965
-----	---------