

Photocell Receptacle (0-480V)

For fixtures that are not equipped with a twist-lock receptacle to accommodate a photocell



INSTALLATION

Disconnect power to the fixture. Remove the blanking cover on the fixture and secure the receptacle using the provided gasket and screws ensuring the north arrow is properly aligned. Rewire the fixture according to the diagram below.

Install the photocell into the receptacle by pushing it down and twisting it clockwise. Note that the receptacle is keyed and can only be inserted in one orientation.

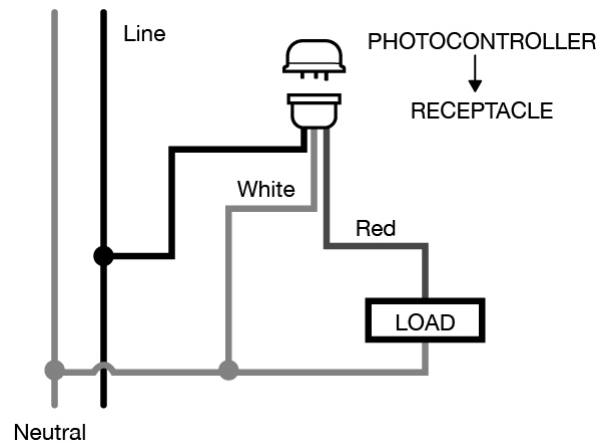

TECHNICAL PARAMETERS



Applicable Voltage	0-480V
Rated Frequency	50/60Hz
Suggested Loading	AWG#18: 10Amp; AWG#14: 15Amp
Operating temp	-40°C to 70°C
Related Humidity	99%
Approx. Weight	80g
Leads	6" min

DIMENSIONS

