

WARNINGS



RISK OF FIRE, ELECTRICAL SHOCK, CUTS OR OTHER CASUALTY HAZARDS

Installation and maintenance of this product must be performed by a qualified electrician. This product must be installed in accordance with the applicable installation code by a person familiar with the construction and operation of the product and hazards involved.

RISK OF FIRE AND ELECTRIC SHOCK

Make certain power is OFF before starting installation or attempting any maintenance. Disconnect power at fuse or circuit breaker.

RISK OF FIRE

Refer to product label for specific minimum supply conductor requirements.

RISK OF BURN

Disconnect power and allow fixture to cool before handling or servicing.

RISK OF PERSONAL INJURY

Fixture may become damaged and/or unstable if not installed properly.

DISCLAIMER OF LIABILITY: CSC LED assumes no liability for damages or losses of any kind that may arise from the improper, careless, or negligent installation, handling or use of this product.

NOTICE: Green ground wire is provided in proper location. Do not relocate.

SAFETY: This fixture must be wired in accordance with the National Electrical Code and applicable local codes and ordinances. Proper grounding is required to ensure personal safety. Carefully observe grounding procedure under installation section.

APPLICATIONS: This lighting fixture is designed for indoor lighting applications, and should not be used in an area with limited ventilation or inside high ambient temperature enclosures. It must be stored in a dry location prior to installation.

ATTENTION RECEIVING DEPARTMENT: Note actual fixture description of any shortage or noticeable damage on delivery receipt. File claim for common carrier (LTL) directly with carrier. Claims for concealed damage must be filed within 15 days of delivery. All damaged material, complete with original packaging must be retained.

WALL MOUNT (OPTIONAL; COMPATIBLE WITH UPLIGHT MODULE)

1. Remove lens and LED reflector strip. (Fig. 1)
2. Secure wall mount bracket to the wall. (Fig. 2)
Note: For distance of the holes, refer to Fig. 3
3. Secure wall mount bracket to the fixture. Holes will need to be drilled in the fixture housing to accomplish this. (Fig. 4)
Note: A template is included on the last page for your reference.

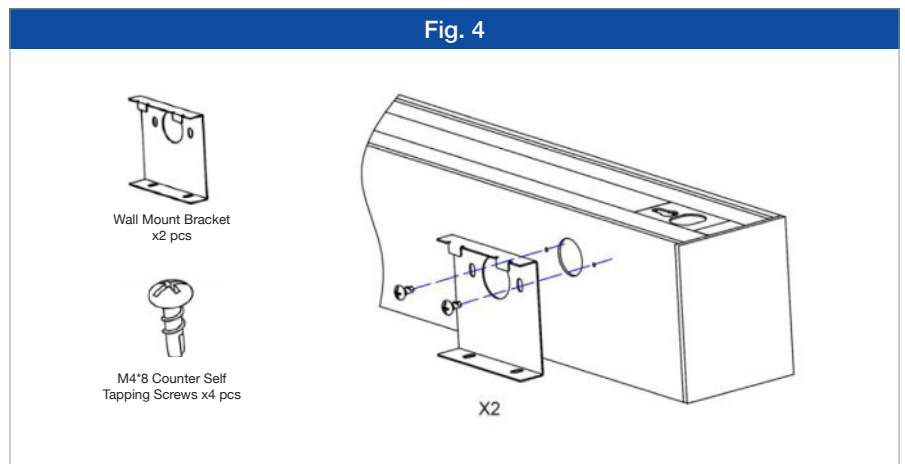
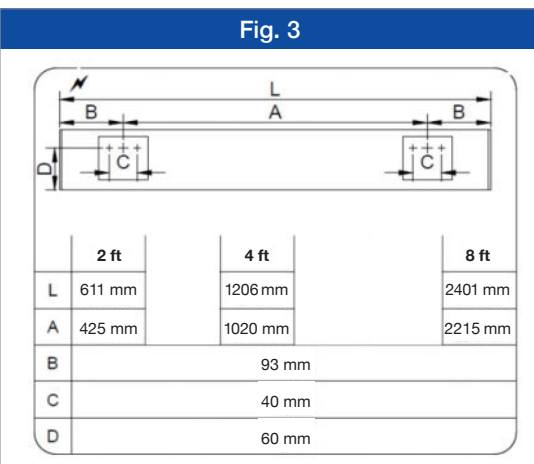
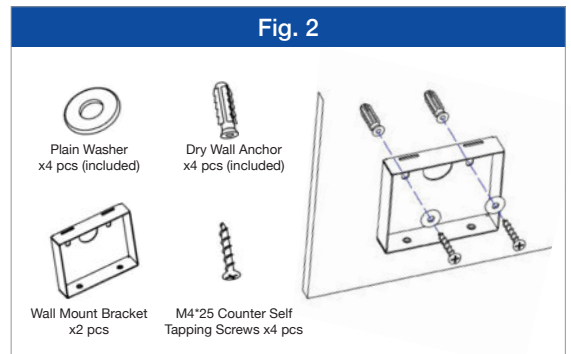
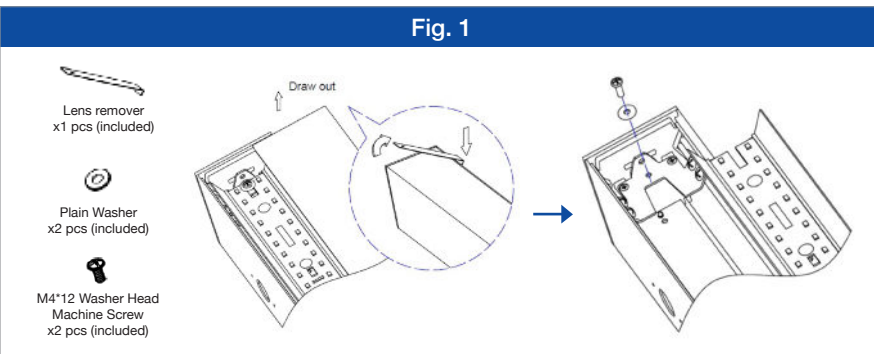

- Run cable through the hole on the wall mount bracket and fixture (Fig. 5). The LED reflector strip and lens may now be reinstalled.
- Hang the light fixture on the wall mount bracket (Fig. 6).
- Secure the two halves of the wall mount bracket together with screws.

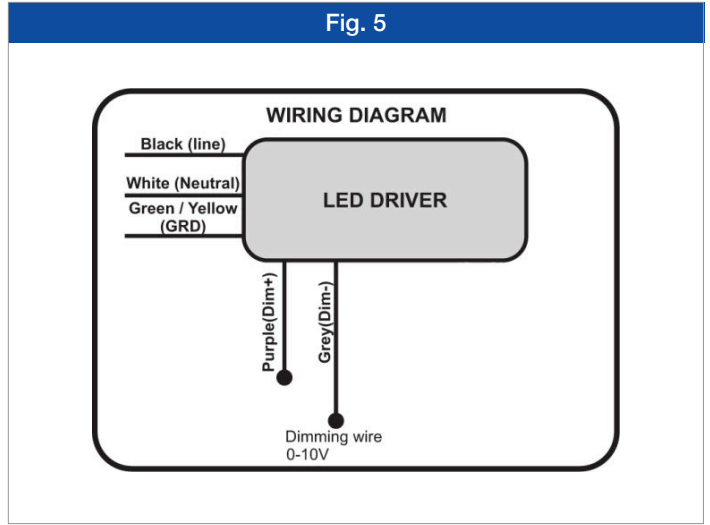
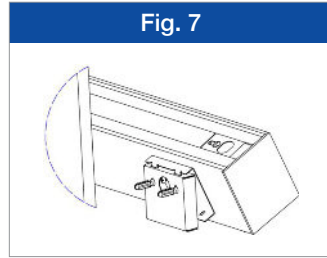
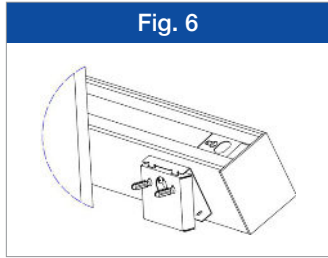

FOR CONTINUOUS ROW MOUNT

Install connection plates and screws to connect fixtures as required.

Then follow the steps shown above to install the wall mount brackets. (Refer to the dimensions below for the distance of holes between 2 fixtures.)

