

SATURN

1901SS

LARGE POST TOP OR PIER MOUNT LANTERN

Saturn is a stunning, modern design offering robust construction and intersecting lines that create a striking contrast against the clear seeded glass.

DETAILS	
FINISH:	Stainless Steel
MATERIAL:	Stainless Steel
GLASS:	Etched Opal
DIMMABLE:	No

DIMENSIONS	
WIDTH:	10"
HEIGHT:	21.8"
WEIGHT:	10lb

LIGHT SOURCE	
LIGHT SOURCE:	Socketed
WATTAGE:	1-12w Med. LED, 100w Equiv.
VOLTAGE:	120v

SHIPPING	
CARTON LENGTH:	13.5
CARTON WIDTH:	13.5
CARTON HEIGHT:	25
CARTON WEIGHT:	13

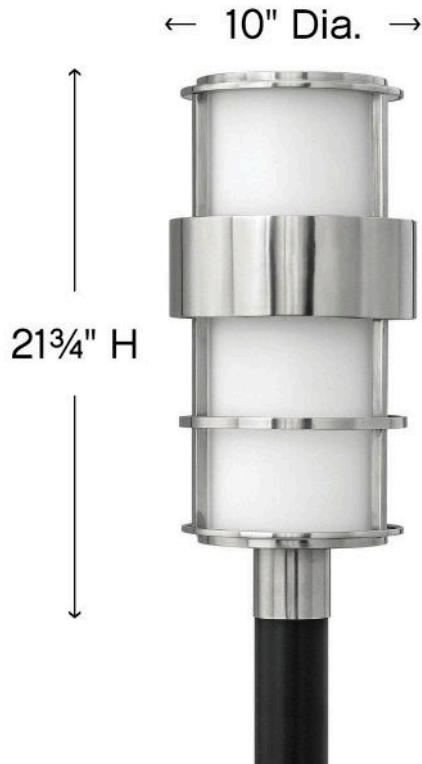

PRODUCT DETAILS:

- Suitable for use in wet (outdoor direct rain or sprinkler) locations as defined by NEC and CEC. Meets Underwriters Laboratories & CSA Canadian Standards Association Product Safety Standards
- 2-year finish warranty
- Bold lines and a clean, minimalist style complement contemporary architecture
- Stainless steel provides superior strength and performance

HINKLEY

HINKLEY
33000 Pin Oak Parkway
Avon Lake, OH 44012

PHONE: (440) 653-5500
Toll Free: 1 (800) 446-5539

hinkley.com