

Whole Family

KVF-XXXXX-TDWJN 12V/ 24VDC  
30W 60W 80W 96W 100W  
120W 150W 200W 300W



■Features

- Output constant voltage
- UL, cUL listed, Class 2, Class P, Type HL
- Universal AC input: 100-277VAC
- Power Factor: up to 0.98
- High efficiency : up to 83%
- Dimming range: 0-100%
- Load: 10-100%
- Protection:short circuit/over loading/ Over temperature
- PWM output, does not change the color index
- Full protection aluminum housing, for dry, damp and wet location
- Flicker-free
- Compatible with Forward phase, Reverse phase, Triac, MLV, ELV Dimmers
- Cooling by free air convection
- Suitable for LED lighting and moving sign applications



TYPE HL



Class 2

■Specification

Model		KVF-24096-TDWJN
Certificates		FCC UL cUL Class 2
Output	DC Voltage	24V
	Rated Current	4A
	Rated Power	96W
	Voltage Tolerance	±0.5V
	Voltage Regulation	±0.5%
	Load Regulation	±1%
Input	Voltage Range	100-277VAC
	Frequency Range	47-63Hz
	Power Factor (Typ.) @ full load	0.98@120VAC 0.96@277VAC
	THD (Typ.) @ full load	<20%
	Efficiency (Typ.) @ full load	83%
	AC Current (Max.)	1.3A@100VAC
	Inrush Current (Typ.)	20A, 50%, 1.6ms
	Leakage current	<0.50mA
Protection	Short Circuit	shut down o/p voltage, re-power on to recover after fault condition is removed
	Over Loading	≤120% constant current limiting, auto-recovery
	Over temperature	100°C±10°C shut down o/p voltage, automatically recover after cooling.
Environment	Working TEMP.	-40~+60°C (see below derating curve)
	Working Humidity	20~90%RH, non-condensing
	Storage TEMP. Humidity	-40~+80°C, 10~95%RH
	TEMP .coefficient	±0.03%/°C (0~50°C)
	Vibration	10~500Hz, 5G 10min./1 cycle,period for 60min. each along X,Y,Z axes
Safety& EMC	Safety standards	UL8750+UL1310
	Withstand voltage	I/P-O/P:1.88KVAC
	Isolation resistance	I/P-O/P:100MΩ/500VDC/25°C/70%RH
	EMC EMISSION	FCC Part 15 B
others	Net. Weight	1.3Kg
	Size	220*94.5*40mm (L*W*H)
	packing	10PCS/CTN

## Phase cut /Triac dimmable driver-PWM output KVF-TDWJN series 96W

### Notes

1. All parameters if NOT specially mentioned are measured at 120VAC input , rated load and 25°C of ambient temperature.
2. To extend the driver's using life ,please reduce the loading at lower input voltage.

### Derating Curve

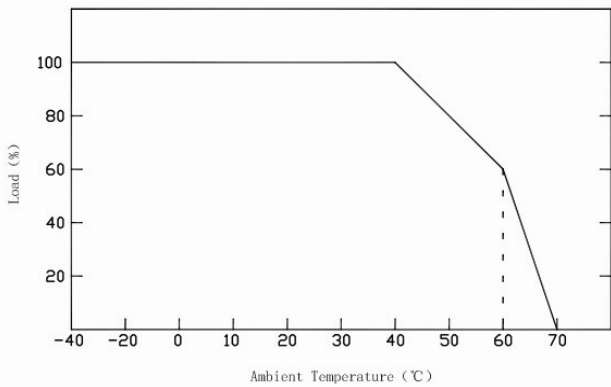

※To extend their life, please refer to the Derating Curve and derate according to the temperature.

### Mechanical Specification

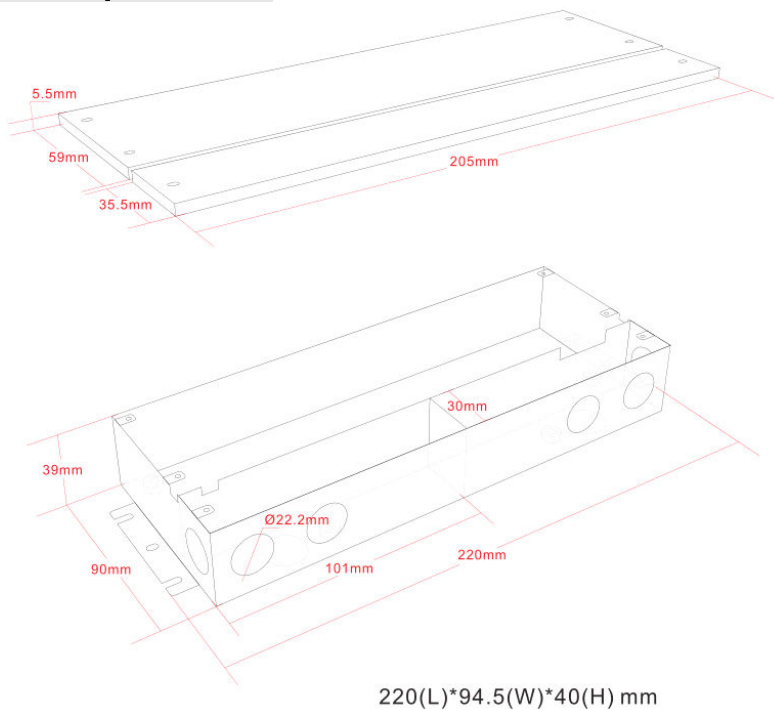

Unite: mm

Tolerance:P 0.5-2mm

※ Input wire 18AWG Black and White to be connected to AC L and N ,Green wire go ground,

※Output wire 16AWG Red to LED Positive side (+) , Black to LED Negative side (-).

### Dimming Operation

※The Pulse-Width Modulation (PWM) of output voltage can be adjusted through input terminal of the AC phase line(L) by connection a phase/triac dimmer.

※Usually matching with Forward phase , leading edge , Magnetic low voltage, triac dimmers, or Reverse phase, trailing edge ,Electric low voltage Dimmers.

※Please try to use dimmers with power at least 1.5 times as the output power of the driver.

■ Connecting Diagram

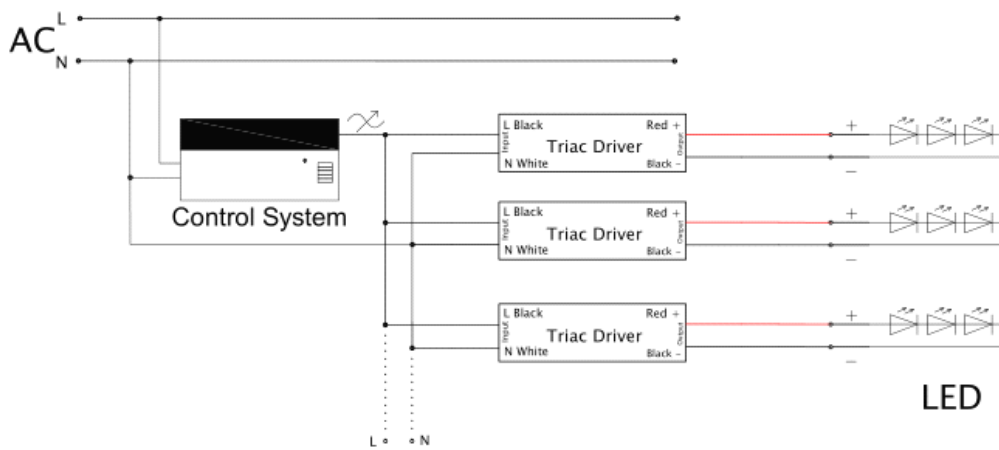
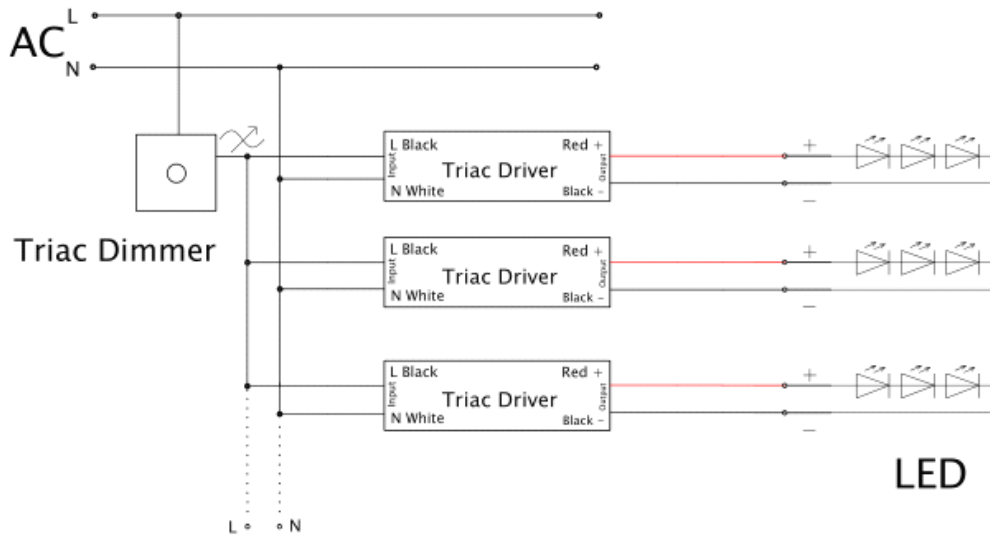
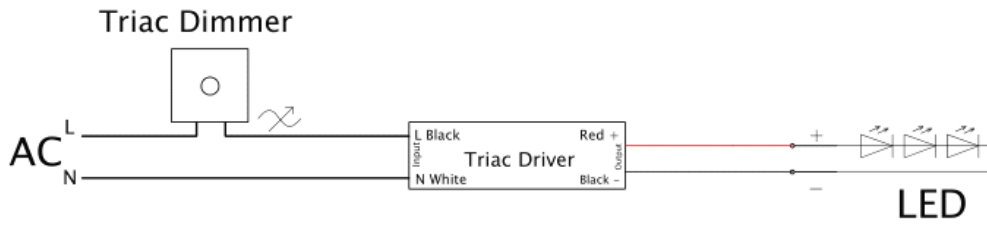

■ Instruction:

- 1) This driver should be installed by qualified and professional person;
- 2) Please make sure the driver is installed with adequate ventilation around it to allow for heat dissipation.
- 3) Ensure that wiring is correct before test in order to avoid light and power supply damage;
- 4) If driver Cannot work normally, don't maintain privately; Have any question, please contact Zhuhai Shengchang.

Please visit our website or contact us for more information! [www.scpower.net.cn](http://www.scpower.net.cn)