

QUESTIONS OR CONCERNS CONTACT CANARM AT:

1-800-265-1833 (English) / 1-800-567-2513 (French)
Monday through Friday 8:00 AM to 5:00 PM E.S.T.

TOOLS AND MATERIALS REQUIRED:



Wire Cutters



Star-headed Screwdriver



Wrench

Wiring supplies as required by the Canadian Electrical Code and/or the Quebec Electrical code

"INSTRUCTIONS PERTAINING TO RISK OF FIRE OR INJURY TO PERSONS"
"READ ALL INSTRUCTIONS"
"IMPORTANT SAFETY INSTRUCTIONS"
"SAVE THESE INSTRUCTIONS"

SAFETY PRECAUTIONS:

1. **TURN OFF ELECTRICAL POWER BEFORE STARTING INSTALLATION OF LIGHT FIXTURE.**
2. **THIS PRODUCT MUST BE INSTALLED IN ACCORDANCE WITH THE APPLICABLE INSTALLATION CODE BY A PERSON FAMILIAR WITH THE CONSTRUCTION AND OPERATION OF THE PRODUCT AND THE HAZARDS INVOLVED.**
3. **CAUTION – RISK OF FIRE. CONSULT A QUALIFIED ELECTRICIAN TO ENSURE CORRECT BRANCH CIRCUIT CONDUCTOR.**
4. **CONNECT THE GROUND WIRE (BARE COPPER OR GREEN) FROM YOUR FIXTURE TO THE GROUND WIRE (BARE COPPER OR GREEN) OR GROUND SCREW IN THE ELECTRICAL OUTLET BOX.**

NOTE: Product may not look exactly as shown in figures.

INSTALLATION:

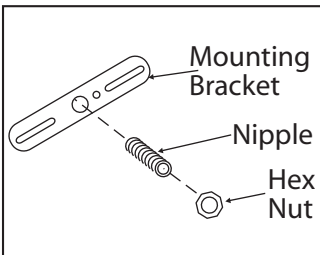

1. Attach nipple to mounting bracket. Adjust so it will clear hole in back of fixture and then lock nipple in place with hex nut.

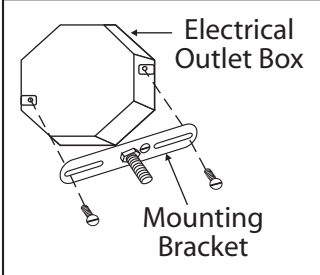

2. Attach mounting bracket to electrical outlet box with electrical box screws (not included).

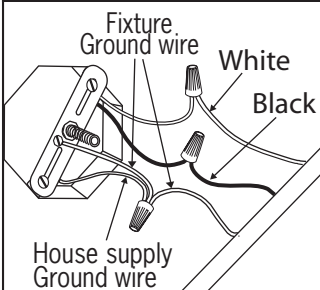

3. Connect the ground wire (bare copper or green) from your fixture to the ground wire (bare copper or green) or ground screw in the electrical outlet box. Connect electrical wires of fixture to wires in electrical box by marretting white wire to white wire, then black wire to black wire.

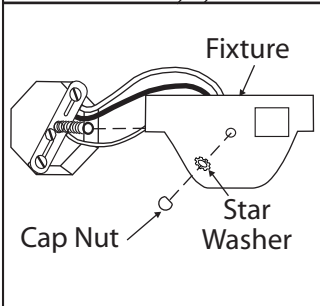

4. Tuck electrical wires into electrical box. Position hole in fixture over nipple and secure in place with cap nut.

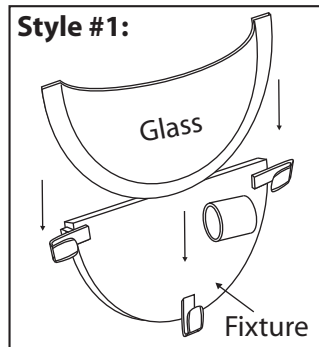

5. **Note:** Refer to the style of assembly that matches the style of your fixture.

Style #1: Install the glass as shown.

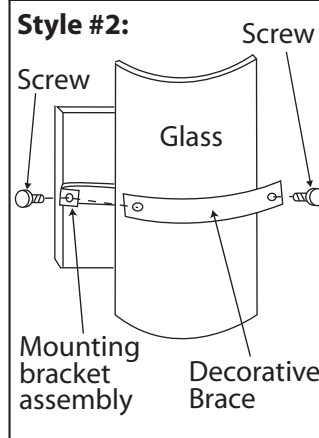

Style #2: Align glass and decorative brace to mounting bracket assembly. Secure in place with 2 (or 4) screws.

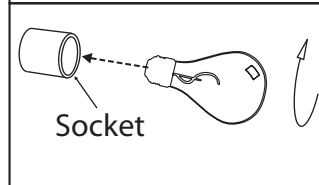

6. Install the proper bulb type and wattage (not included).