

# 2.5 SQUARE STRIP LED WALL/CEILING



Assembly instructions  
Y503-10820  
rev 1.2



*Attention: Read and understand these instructions before installing fixture. This fixture is intended for installation in accordance with National Electric Code and local regulation: To assure full compliance with local codes and regulations, check with your local electrical inspector before installation. This equipment is guaranteed only when used as indicated in these instructions; Therefore they should be kept for future reference. To prevent electrical shock, turn off power supply before carrying out any connection or maintenance operations.*

## STEP 1

Make sure you have all the elements of the fixture

Your box should contain the following parts

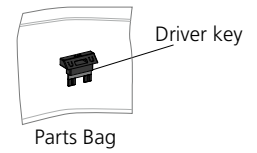
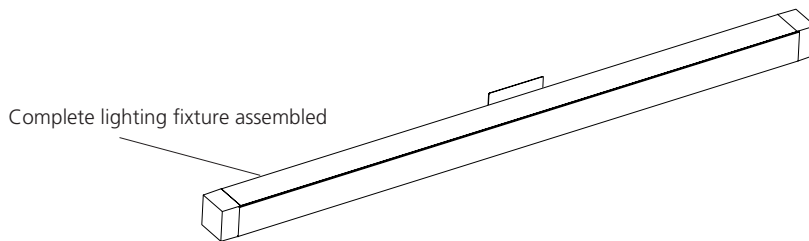

Phase control / 2-wire dimming models only  
RD90\*L\*\*\*\*6A

## STEP 2

- 2.1 Remove the clip-on diffuser.
- 2.2 Remove the 4 Philips Screws holding the backplate onto the fixture.

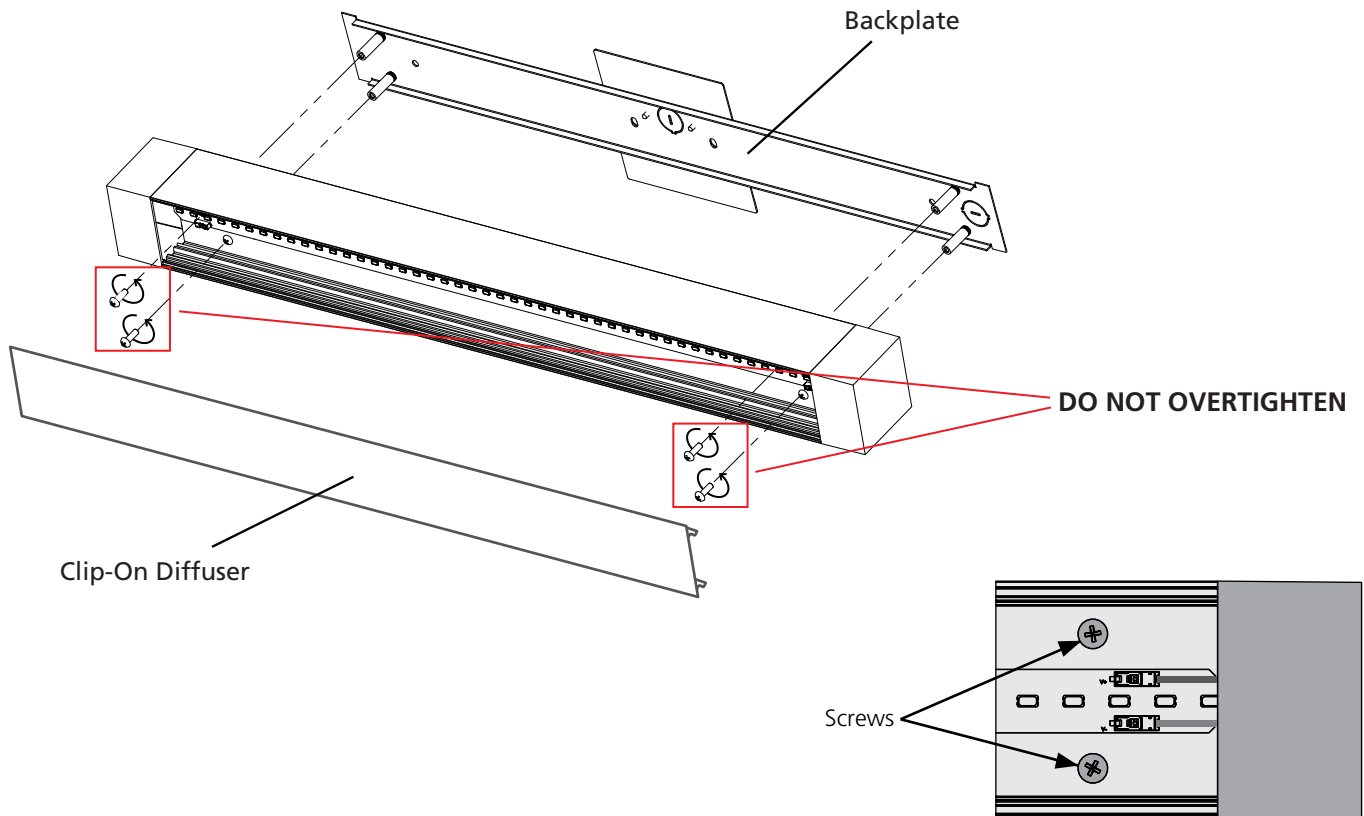

# 2.5 SQUARE STRIP LED WALL/CEILING



Assembly instructions  
Y503-10820  
rev 1.2

**OPTIONAL** Decreasing luminaire output (Phase control/2-wire dimming models only - RD90\*L\*\*\*\*6A)

If you would like to lower the luminaire's light output (as well as the power consumption) by one third, you may do so by replacing the driver key with the one supplied in the parts bag. High Output is the default configuration. The following diagram represents the measured ratings with the different keys:

	Strip 26	Strip 37	Strip 49
<b>High Output</b>			
Input Power	15W	23W	31W
Required Key	<b>K</b>	<b>K</b>	<b>A</b>
<b>High Efficiency</b>			
Input power	10W	15W	20W
Required Key	<b>U</b>	<b>U</b>	<b>N</b>

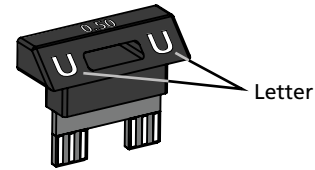

Key found in parts bag

- Using a fingernail into the slot or by prying the slot (carefully as to not damage the luminaire), remove the key by pulling straight up.
- Insert the other key.

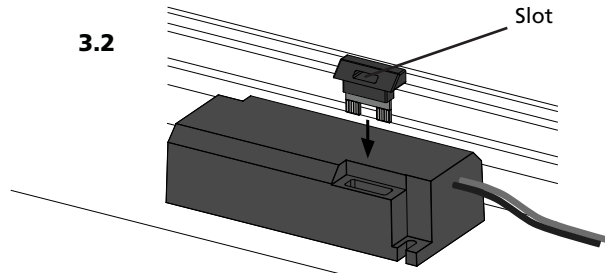
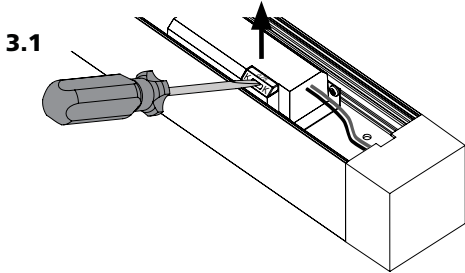

**STEP 3A** The fixture can be installed over an electrical junction box or using an armored cable connection.  
-For Direct Wire installation (armored cable/BX connection, "pigtail"), follow the steps below;  
-For standard installation over an electrical Junction Box, skip to page 4 (STEP 3B).

**NOTE: The cable entry opening is offset from the center of the backplate, see dimensions below.**  
3A.1 Calculate the armored cable position in relation to the mounting points using the measurements below. Pre-drill mounting holes according to surface condition and selected mounting hardware (not supplied)

**2FT MODEL**

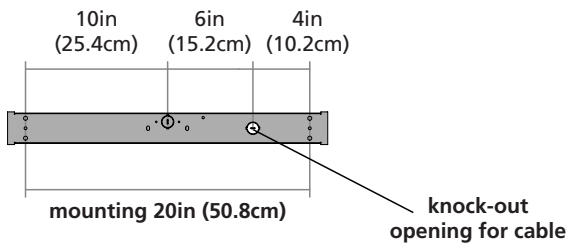

**3FT MODEL**

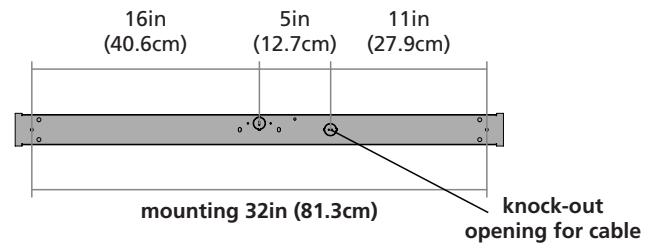

**4FT MODEL**

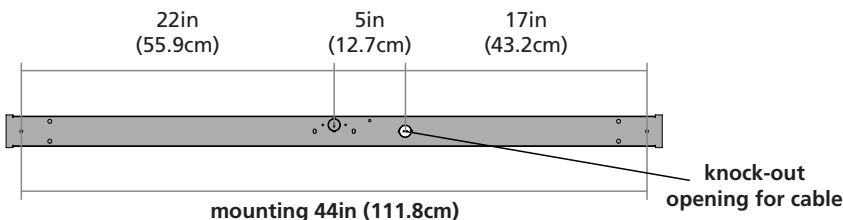

## 2.5 SQUARE STRIP LED WALL/CEILING



Assembly instructions  
Y503-10820  
rev 1.2

### STEP 3A (continued)

- 3A.2 Connect the electrical feed to the back plate of the fixture through the 3/4" knock-out opening
- 3A.3 Mount the back plate to the wall/ceiling using the appropriate screws and anchors (not supplied)
- 3A.4 Make the electrical connection to the backplate wiring harness
- 3A.5 Connect the backplate and fixture's yellow connectors (and black if installing 0-10V model - RD90\*L\*\*\*08A)
- 3A.6 Mount the fixture to the back plate using the four screws removed in STEP 2.2
- 3A.7 Clip the diffuser back on. Installation is now complete.

3A.2

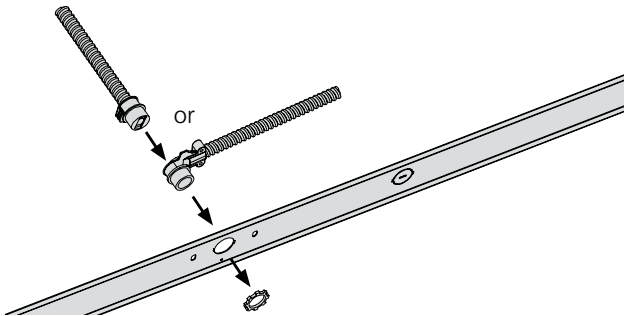

3A.3

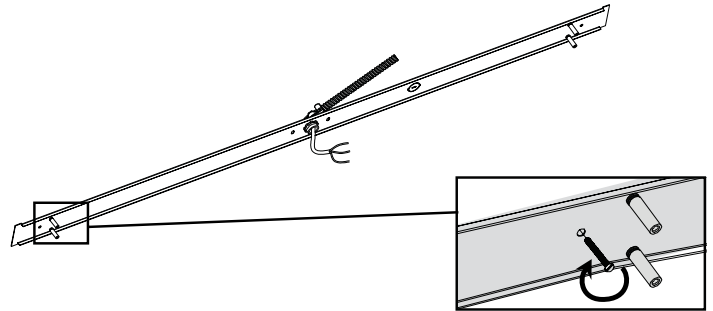

3A.4

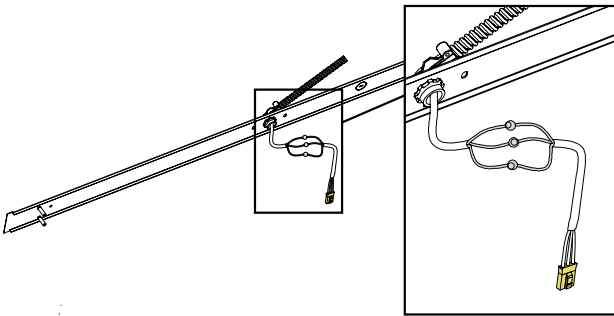

3A.5

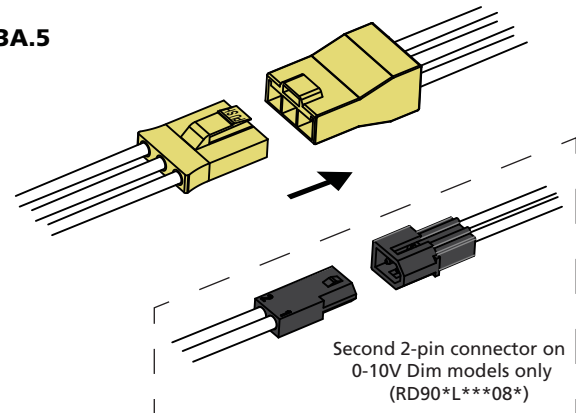

3A.6

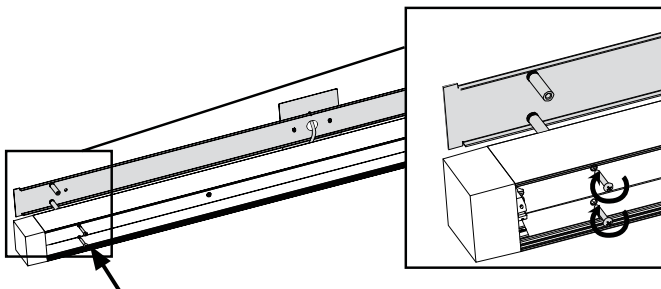

3A.7

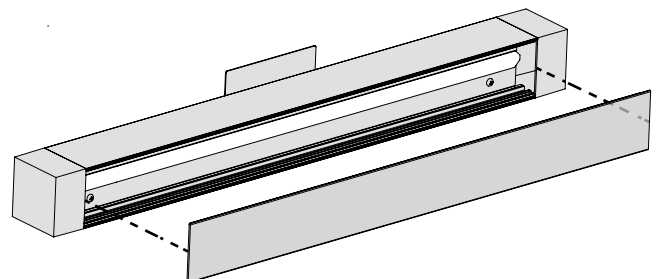

# 2.5 SQUARE STRIP LED WALL/CEILING



Assembly instructions  
Y503-10820  
rev 1.2

## STEP 3B

For installation on standard electrical Junction Box

- 3B.1 Pre-drill mounting holes according to surface condition and selected mounting hardware (not supplied) using the measurements below.
- 3B.2 Make the electrical connection to the fixture, passing through the backplate.
- 3B.3 Mount the back plate to the wall/ceiling using the appropriate screws and anchors (not supplied).
- 3B.4 Connect the backplate and fixture's yellow connectors (and black if installing 0-10V model - RD90\*L\*\*\*08A)
- 3B.4 Mount the fixture to the back plate using the four screws removed in STEP 2.2

D = Distance center to center

- 2.5 Square Strip 26: D=20" (50.8cm)
- 2.5 Square Strip 37: D=32" (81.3cm)
- 2.5 Square Strip 49: D=44" (111.8cm)

### 3B.1

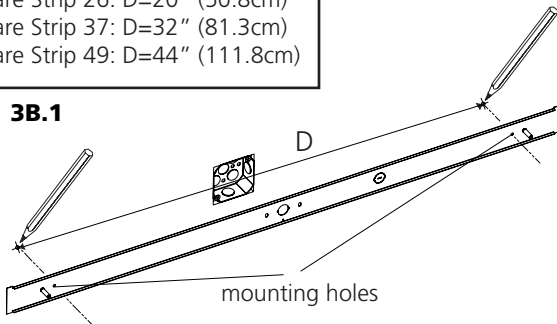

### 3B.2

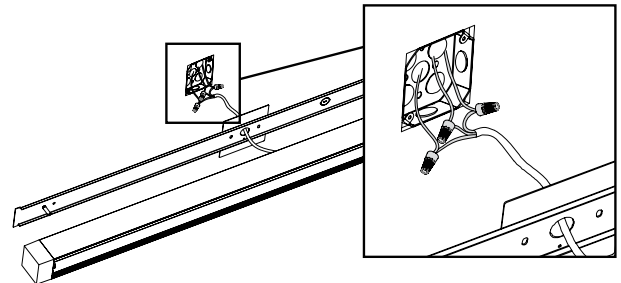

### 3B.3

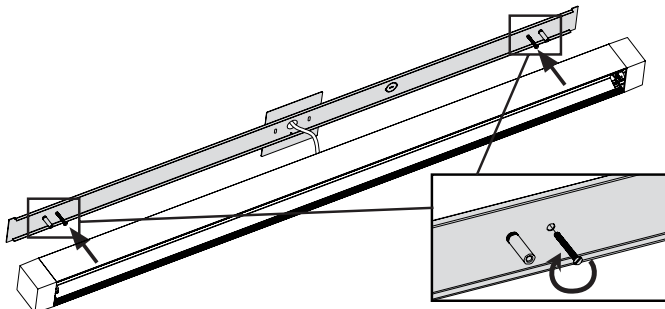

### 3B.4

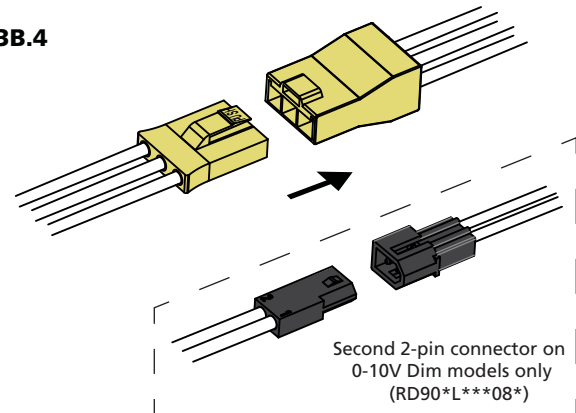

### 3B.5

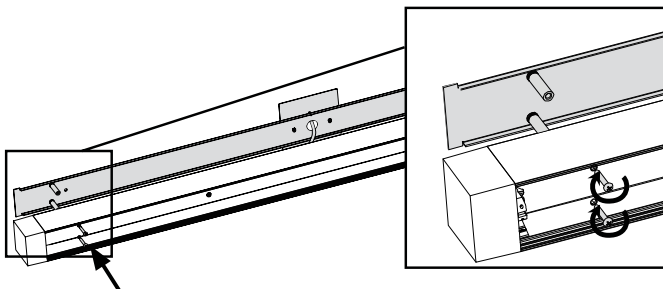

### 3B.6

