

Artemide®

Orsa Cluster 5

design
Foster + Partners

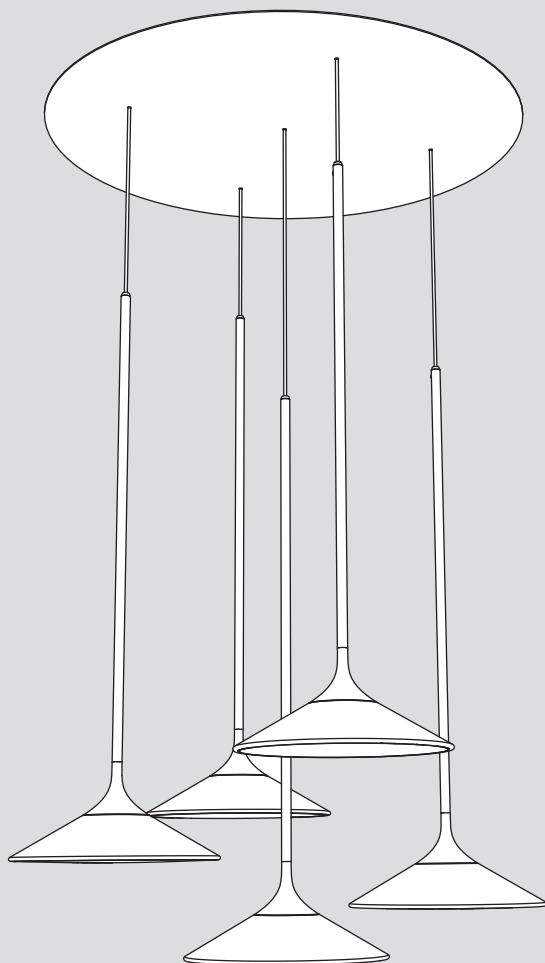



i

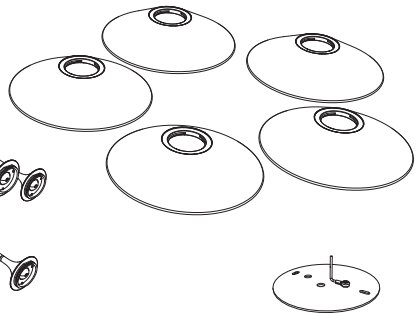
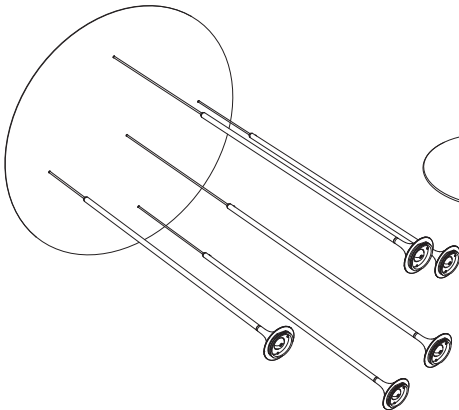
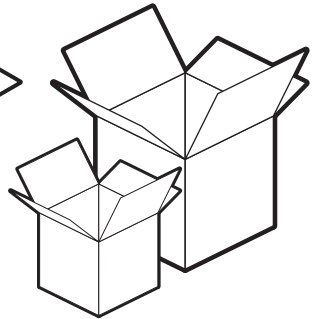
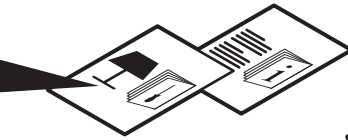

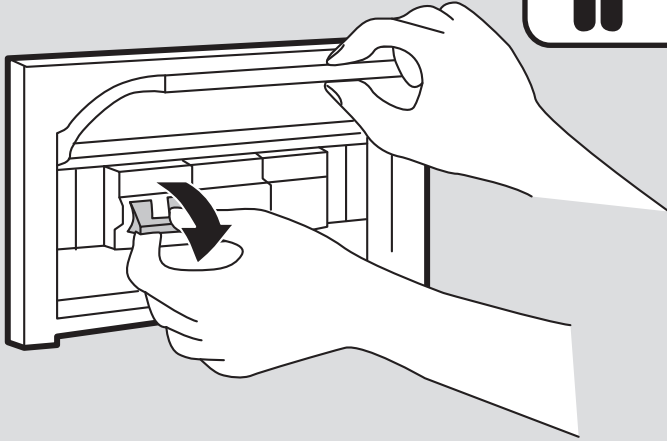
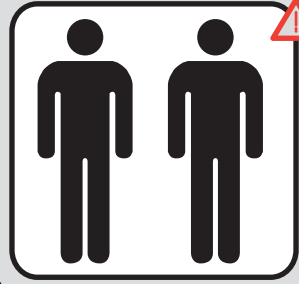

1

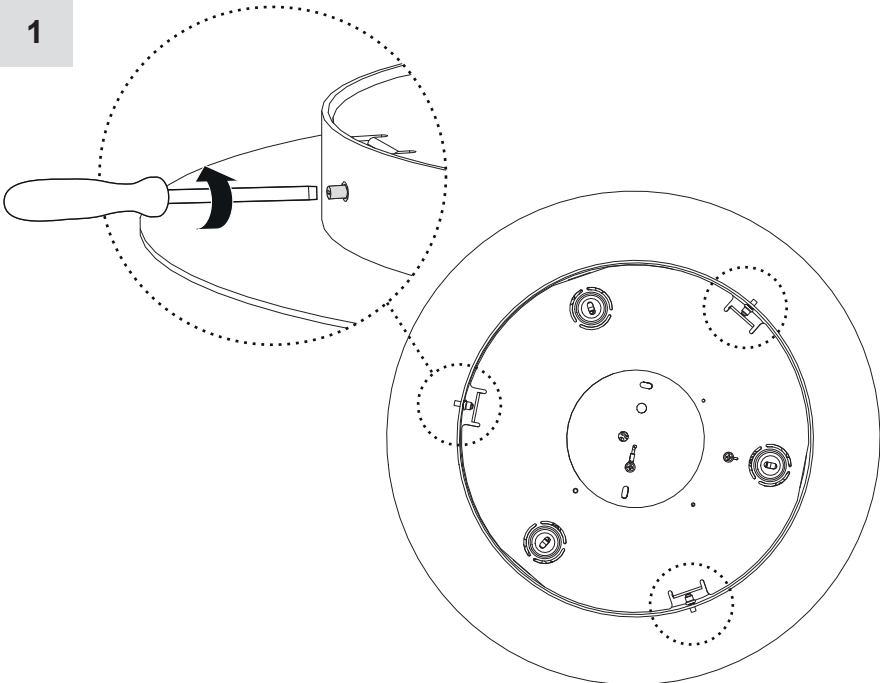

2

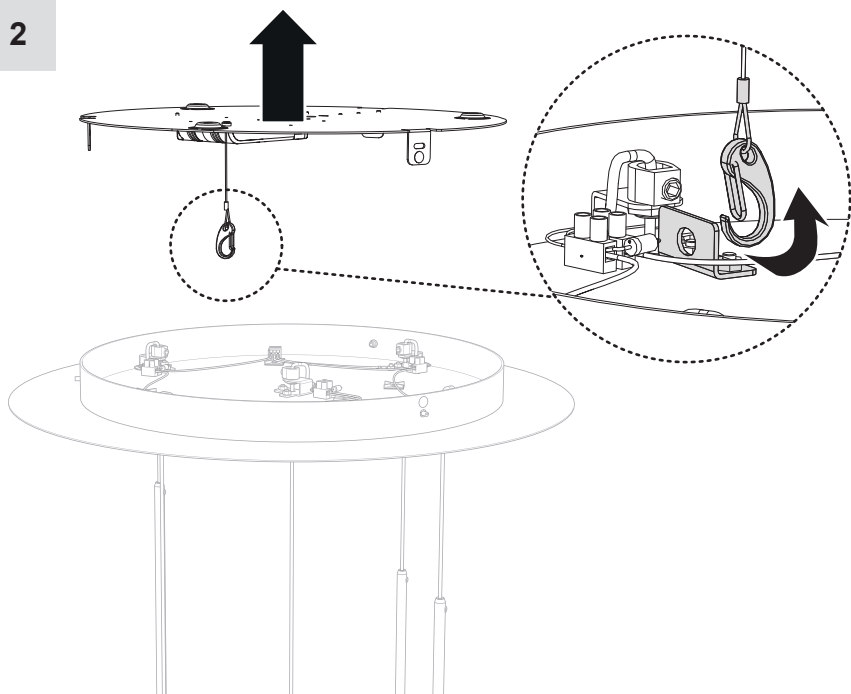

3a



For voltage refer to lamp driver
 Pour la tension, se référer au driver de la lampe
 Para el voltaje consultar el alimentador de la lámpara

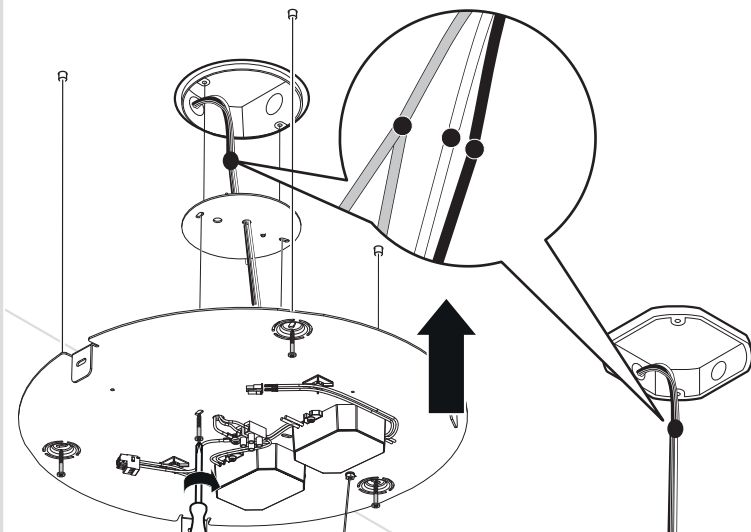

- | | | |
|--------------------|--|--------------------|
| white/blanc/blanco | | white/blanc/blanco |
| green/vert/verde | | green/vert/verde |
| black/noir/negro | | black/noir/negro |

3b

120 V

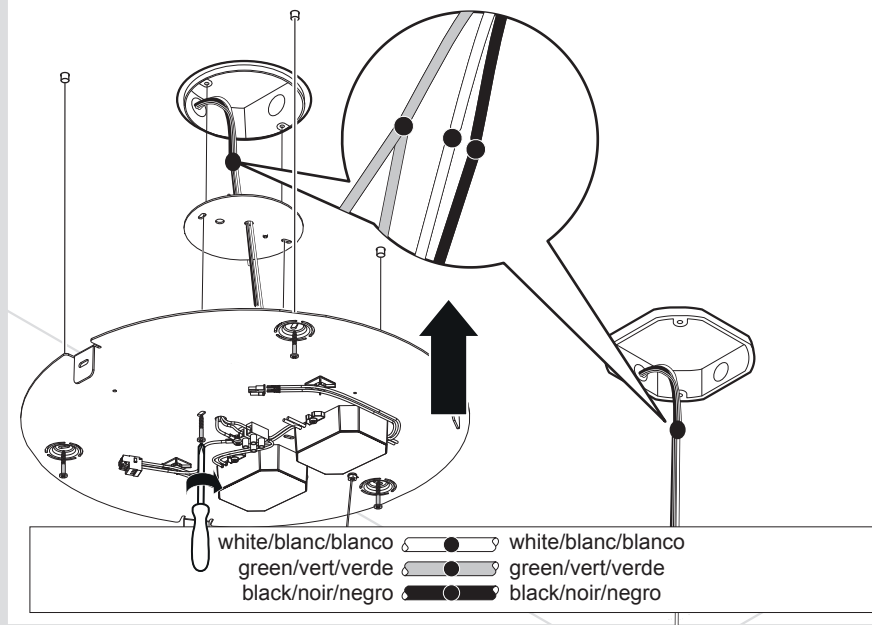
 Phase cut
 Coupure de phase
 Corte de fase
**3c**

120-277 V

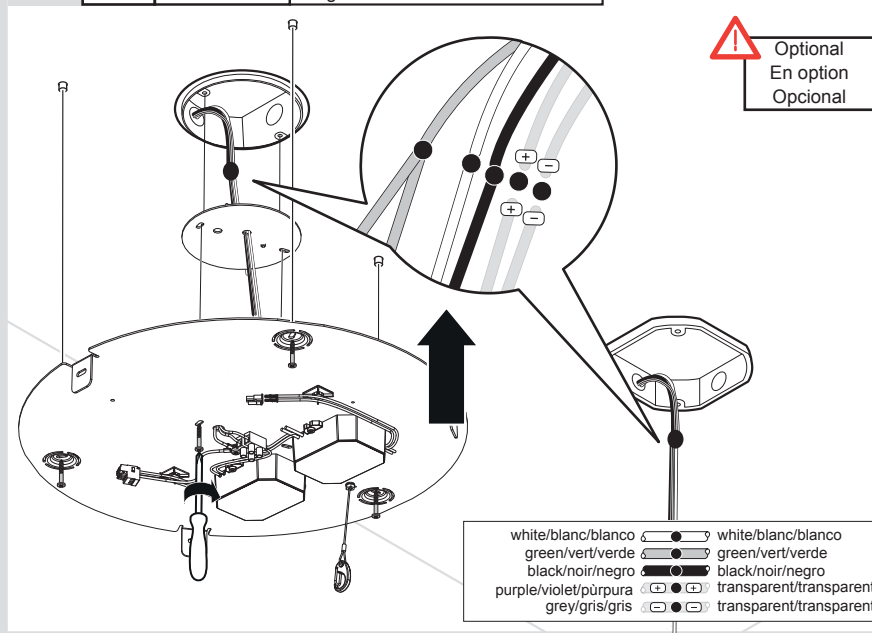
 1-10 V dimming control
 Dimmable 1-10 V
 Regulable mediante control 1-10 V

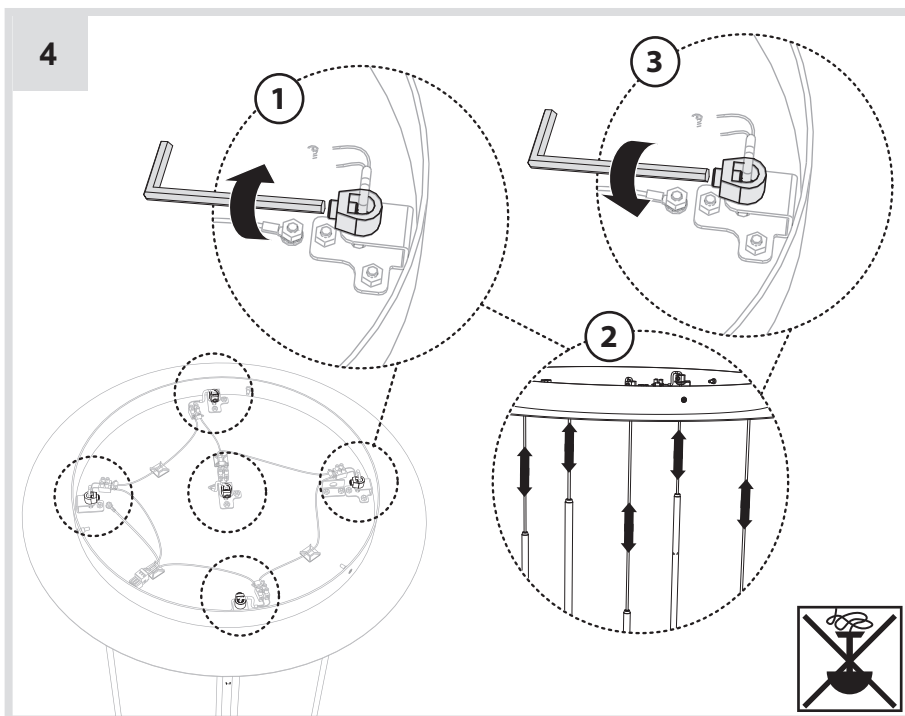
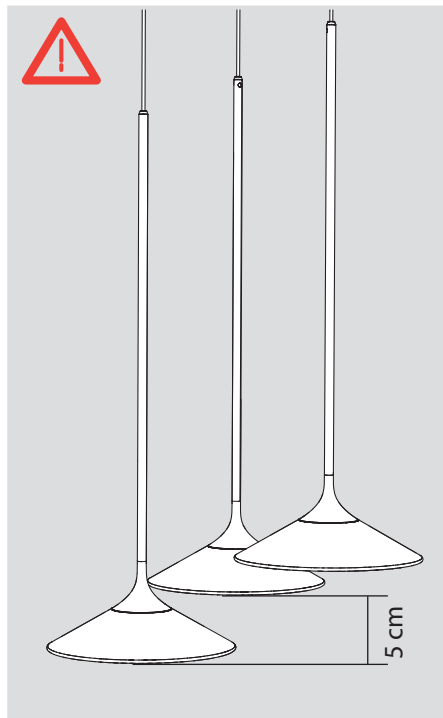
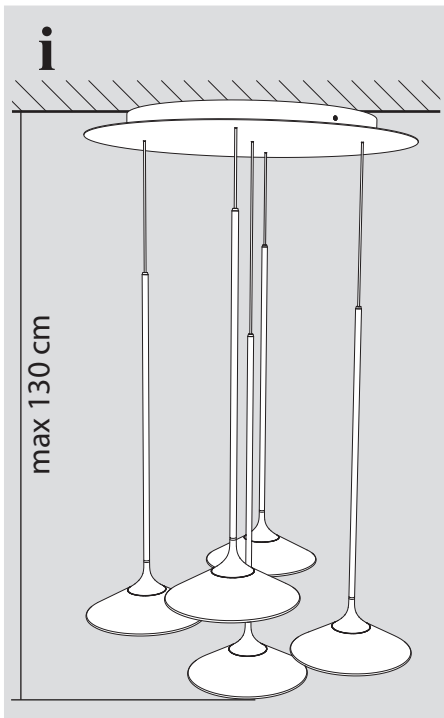

5

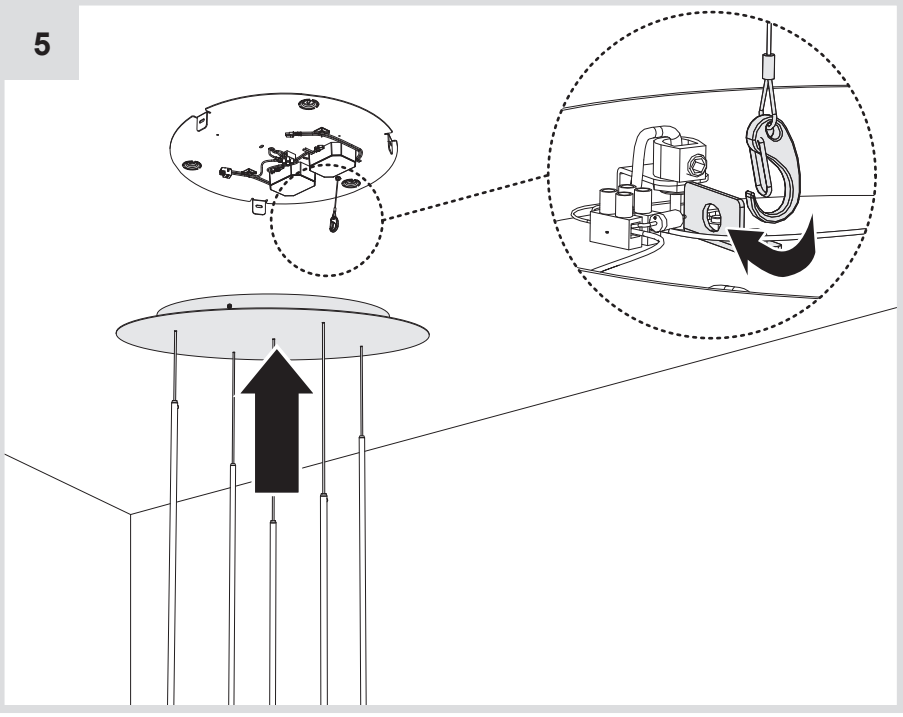

6

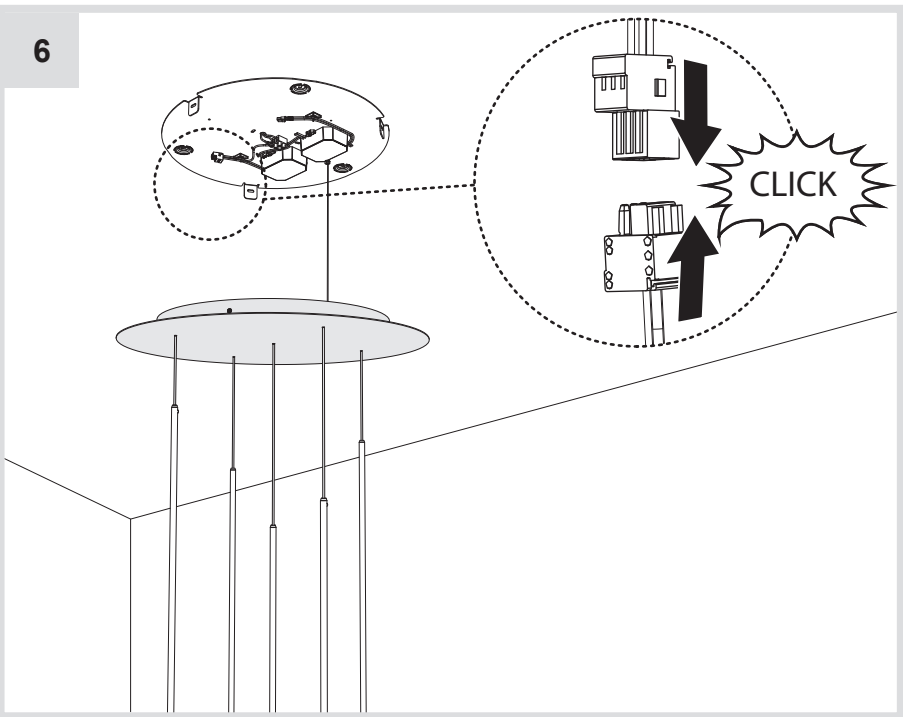

7

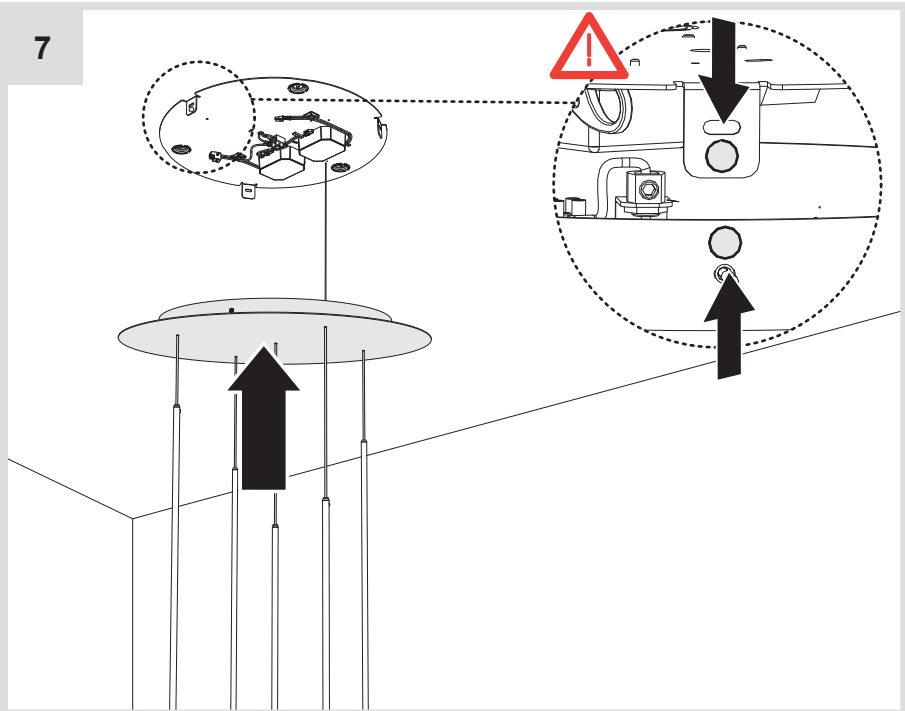

8

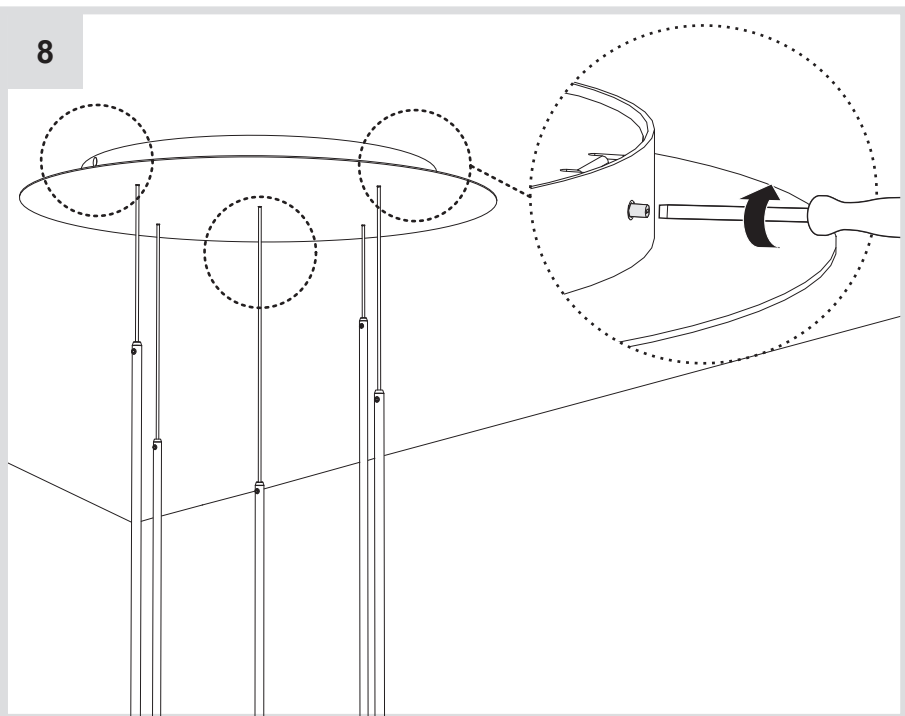

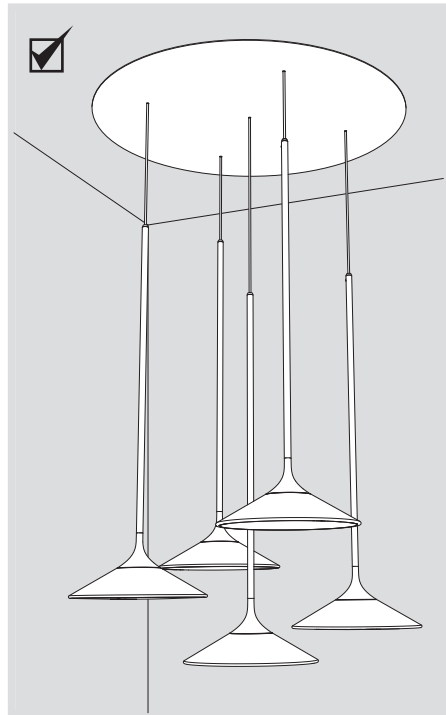
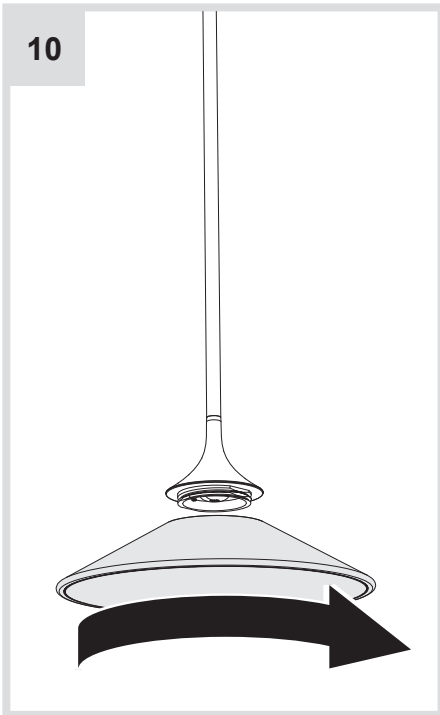
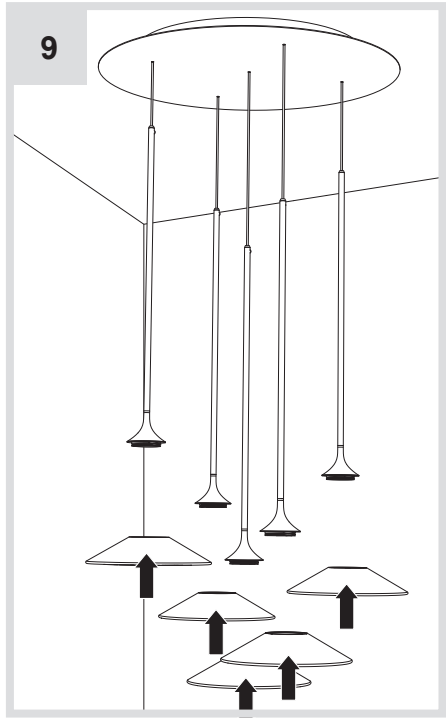
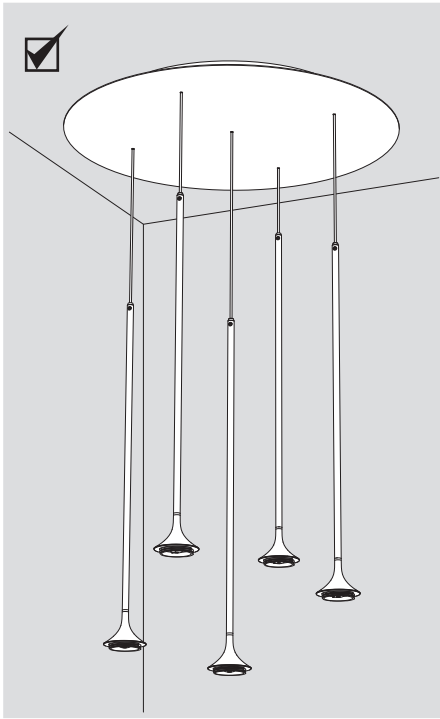

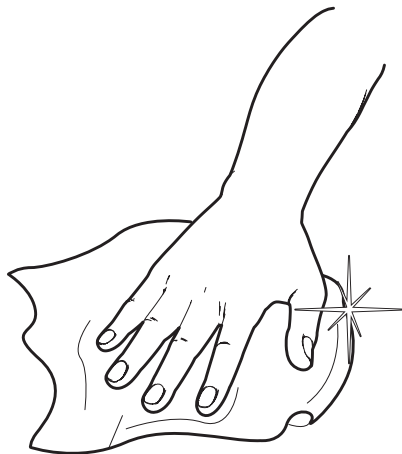

Artemide®



Artemide

via Bergamo, 18
20010 Pregnana M.se (MI)
ITALIA

tel. +39 02 935 181
fax +39 02 935 90 254
fax +39 02 935 90 496

www.artemide.com

VAT IT00846890150

Artemide Inc.

250 Karin Lane
Hicksville, NY 11801

Tel. 631 694 9292
Toll Free 1-877-Art-9111
Fax 631 694 9275

www.artemide.net

Artemide Ltée/Ltd.

11105 rue Renaude Lapointe
Montréal, Québec H1J 2T4

Tel. 514 323 6537
Toll Free 888 777 2783
Fax 514 323 8864

www.artemide.net

cod. Y513000799